



SERVICE PARTS LIST

BULLETIN NO.
54-24-5010

SPECIFY CATALOG NO. AND SERIAL NO. WHEN ORDERING PARTS		REVISED BULLETIN	DATE
M18™ FUEL™ Brushless Hammer-Drill			Aug. 2018
CATALOG NO.	2804-20	STARTING SERIAL NO.	J77A
		WIRING INSTRUCTION SEE PAGE 2	

FIG.	PART NO.	DESCRIPTION OF PART	NO. REQ.
1	05-88-0019	M8.0 x 1 LH T-40 Chuck Screw	(1)
2	42-66-1006	1/2" Keyless Chuck	(1)
13	06-82-7336	M4 x 20mm Pan Hd. ST T-10 Screw	(4)
14	06-82-7337	M4 x 20mm Washer Pan Hd. ST T-10 Scr.	(4)
16	42-42-3001	Forward/Reverse Shuttle	(1)
17	45-24-1045	Speed Change Lever	(1)
19	-----	Left Housing Halve - Support	(1)
20	-----	Belt Clip	(1)
21	06-82-2500	6-32 x 7mm Pan Hd. Taptite T-15 Screw	(2)
31	-----	Secondary Clamp Body	(1)
32	-----	Primary Clamp Body	(1)
33	-----	Threaded Side Handle	(1)
34	44-10-4002	Speed Selector Slide	(1)
35	40-50-9001	Detent Spring	(1)
36	-----	Right Housing Halve - Cover	(1)
38	-----	Bit Holder with Clip	(1)
39	06-82-6350	M3 x 16mm Pan Hd. ST T-10 Screw	(5)

EXAMPLE:
00 0

Component Parts (Small #) Are Included
When Ordering The Assembly (Large #).

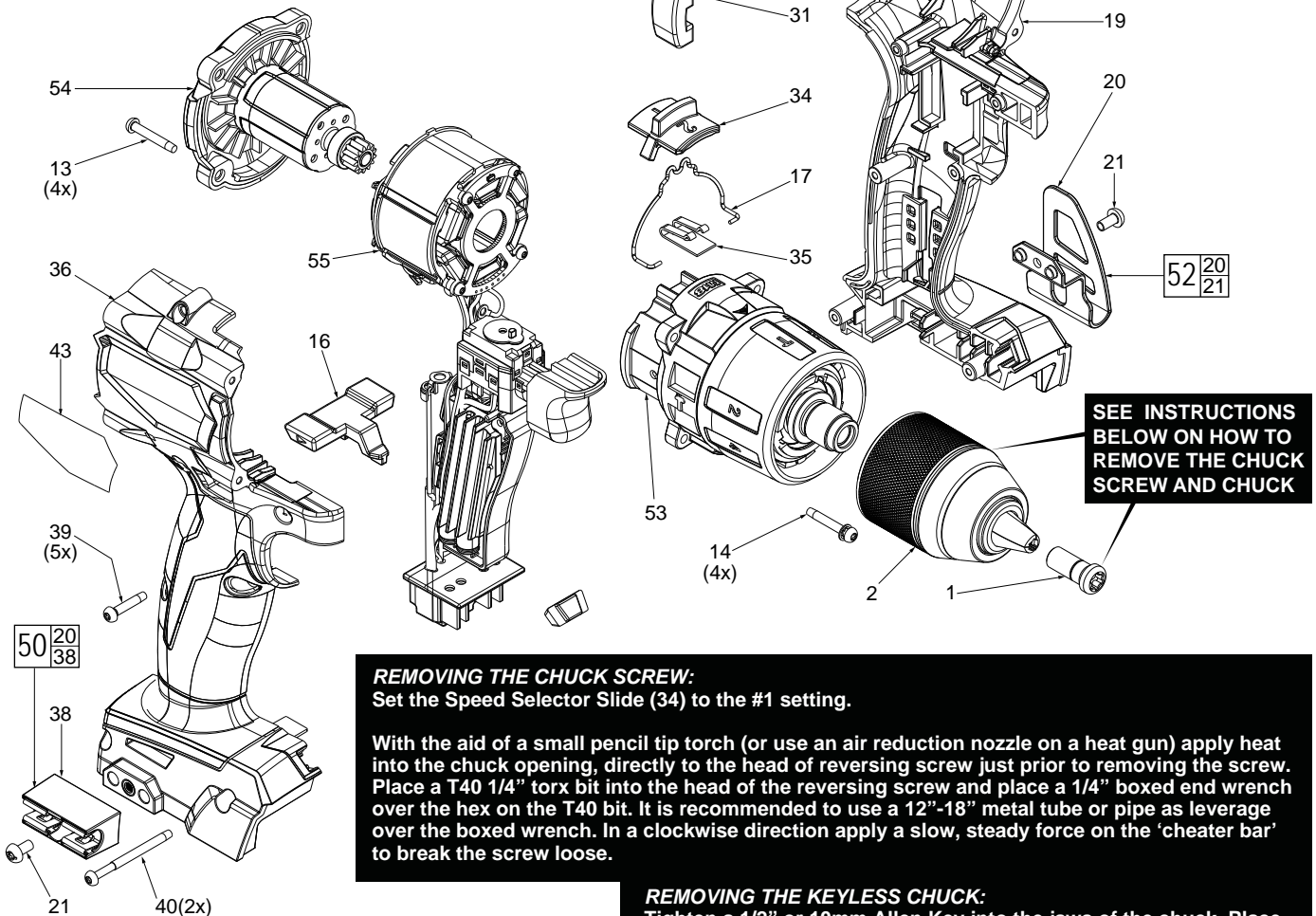

REMOVING THE CHUCK SCREW:
Set the Speed Selector Slide (34) to the #1 setting.

With the aid of a small pencil tip torch (or use an air reduction nozzle on a heat gun) apply heat into the chuck opening, directly to the head of reversing screw just prior to removing the screw. Place a T40 1/4" torx bit into the head of the reversing screw and place a 1/4" boxed end wrench over the hex on the T40 bit. It is recommended to use a 12"-18" metal tube or pipe as leverage over the boxed wrench. In a clockwise direction apply a slow, steady force on the 'cheater bar' to break the screw loose.

REMOVING THE KEYLESS CHUCK:
Tighten a 1/2" or 10mm Allen Key into the jaws of the chuck. Place the tool into a vise with soft jaws (this will require that you remove the belt clip from the tool). It is recommended to use a 12"-18" metal tube or pipe as leverage over the allen key. In a counter-clockwise direction apply a slow, steady force on the 'cheater bar' to break the chuck loose.

INSTALLING NEW CHUCK AND SCREW:
Torque Chuck to 1095 kg/cm (950.418 in/lbs or 28.93 ft/lbs)
Torque Screw to 461 kg/cm (400.130 in/lbs or 33.34 ft/lbs)

FIG.	PART NO.	DESCRIPTION OF PART	NO. REQ.
40	06-82-2367	M3 x 38mm Pan Hd. ST T-10 Screw	(2)
43	12-20-0478	Service Nameplate	(1)
50	43-72-0950	Bit Holder Assembly	(1)
51	31-44-1004	Housing Assembly	(1)
52	42-70-0950	Belt Clip Assembly	(1)
53	14-29-1014	Gearbox Assembly	(1)
54	16-07-1016	Rotor/End Cap Assembly	(1)
55	14-20-1120	Electronics Assembly	(1)
56	42-62-1002	Side Handle Assembly	(1)
57	42-55-9005	Blow Molded Carrying Case	(1)
	10-20-1048	Warning Label (Not Shown)	(1)



Connect ground wire terminal to gear case assembly as shown.

Connector terminals joining gear case assembly to PCBA of the electronics assembly are to be tucked into channel as shown with wires placed down into wire traps.

Watch for pinched wires here.

Be sure that all mechanical and electrical components are placed firmly and squarely in the corresponding cavities of left housing half.

Be very careful and make sure that all wires and the wire ribbon are placed firmly down in wire channels and traps.

Make sure there are no interferences when installing the right housing half.



ATTENTION
OBSERVE PRECAUTIONS
FOR HANDLING
ELECTROSTATIC
SENSITIVE
DEVICES